

Code No: 154AK

JAWAHARLAL NEHRU TECHNOLOGICAL UNIVERSITY HYDERABAD

B. Tech II Year II Semester Examinations, February - 2024

CONTROL SYSTEMS

(Electrical and Electronics Engineering)

Time: 3 Hours

Max. Marks: 75

- Note:** i) Question paper consists of Part A, Part B.
 ii) Part A is compulsory, which carries 25 marks. In Part A, answer all questions.
 iii) In Part B, Answer any one question from each unit. Each question carries 10 marks and may have a, b as sub questions.

PART – A

(25 Marks)

- 1.a) Define control system. [2]
- b) Define closed loop control system with an example. [3]
- c) Calculate the steady state error due to a step input for type 1 system. [2]
- d) What are the standard test signals? [3]
- e) What is the condition for stability while using nyquist plot? [2]
- f) Define phase margin. [3]
- g) Write the effects of lead compensation. [2]
- h) Explain about steady state accuracy. [3]
- i) What are the advantages of state space approach over transfer function approach? [2]
- j) Define state space model. [3]

PART – B

(50 Marks)

- 2.a) Derive the transfer function of a Armature controlled DC Servo motor. [5+5]
- b) What are the effects of feedback? Explain. [5+5]

OR

3. Using block diagram algebra, obtain the closed loop transfer function of the given figure. [10]

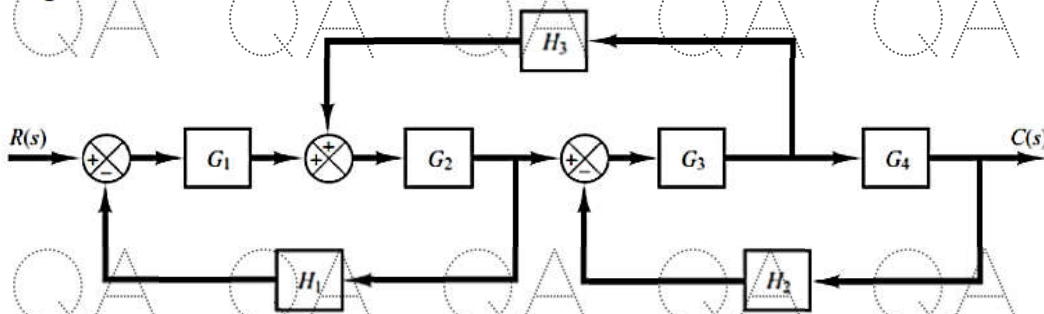

4. Explain in detail the steps involved in construction of Root loci. [10]

OR

5. Using Routh-Hourwitz criteria, determine the number of poles lying on the right half of s plane, left half of s plane and on imaginary axis of the system whose characteristic equation is $S^6+2S^5+8S^4+12S^3+20S^2+16S+16=0$. [10]

6. Plot the bode plot for the given open loop transfer function and obtain the gain and phase crossover frequencies $G(s) = \frac{10}{s(1+0.4s)(1+0.1s)}$. [10]

OR

7. Sketch the polar plot for the following transfer function and determine phase margin and gain margin. $G(s) = \frac{k}{s^2(1+s)(1+2s)}$. [10]

- 8.a) Discuss the procedural steps of lag compensation design in frequency domain.
b) Explain about proportional and derivative controllers with neat sketch. [5+5]

OR

9. Discuss about the Analog and digital implementation of controllers [10]

- 10.a) Determine the state and output equations in vector matrix for the system whose transfer function is given by $G(s) = \frac{s+2}{s(s^2+8s+11)}$.

- b) Obtain the state transition matrix for the state model whose matrix A is given by $A = \begin{pmatrix} 0 & 1 \\ -2 & -3 \end{pmatrix}$ [5+5]

OR

- 11.a) Construct the state space representation of the following differential equation, where y is the output and u is the input

$$\frac{d^3y}{dt^3} + 2\frac{d^2y}{dt^2} + 3\frac{dy}{dt} + y = u$$

- b) Verify whether the following system is observable or not

$$\begin{bmatrix} \dot{x}_1 \\ \dot{x}_2 \end{bmatrix} = \begin{bmatrix} 1 & 2 \\ 2 & 0 \end{bmatrix} \begin{bmatrix} x_1 \\ x_2 \end{bmatrix} + \begin{bmatrix} 1 \\ 2 \end{bmatrix} u. \quad [5+5]$$

---ooOoo---